

Transparent nouns

Contrary to my earlier conviction, a conversation with Michael Ellsworth has persuaded me that the transparent noun phenomenon has to be looked at as complementation to the t-nom, rather than modification by the PP[*of*], because of the rampant occurrence of DNI.

(1) I'll have a cup, thanks.

Chuck's observation that sometimes the *of* can be left out reinforces this:

(2) that type event

So I'll try to develop a version of the semantically inert ('case making') PP[*of*] and a pumping cxn to get transparent nouns out of regular ones. E.g., transparent *cup* out of regular *cup*. Since DNI is part of the story, I'll take a shot at that, too.

I am going to stick to my claim that determiners have to agree with the t-noun head, despite Chuck's ex of

(3) these kind of apples

because I can't think of any other examples of non-agreement with t-noun that don't involve *these* or *those* plus a type/kind/sort noun (see 4). So I'm hoping (3)-type facts (determiner agrees with obj of *of*) can be relegated to a less productive cxn of their own.

- (4)a. *several kind of apples
- b. *three kind of apples
- c. *those bowl of nuts
- d. *this kinds of apple

Also, (3) seems to have a special kind of semantics, not well paraphrased by 'these kinds of apples', 'this kind of apples, or even 'these apples', but better by 'apples of this kind'. So it isn't exactly as if *kind* were simply transparent.

Taking this tack, if it can be maintained, permits one the attractive generalization that the t-noun-headed NPs are syntactically normal and that therefore that the ordinary head-complement-cxn is at work in licensing t-noun-headed NPs as well as the DNPs that have t-noun headed NP complements. That is, this approach lets us do all the work with a lexical entry we need anyway (inert *of*), a pumping cxn taking ordinary nouns to t-nouns, along with lexical entries for the inherently-t-nouns as needed.

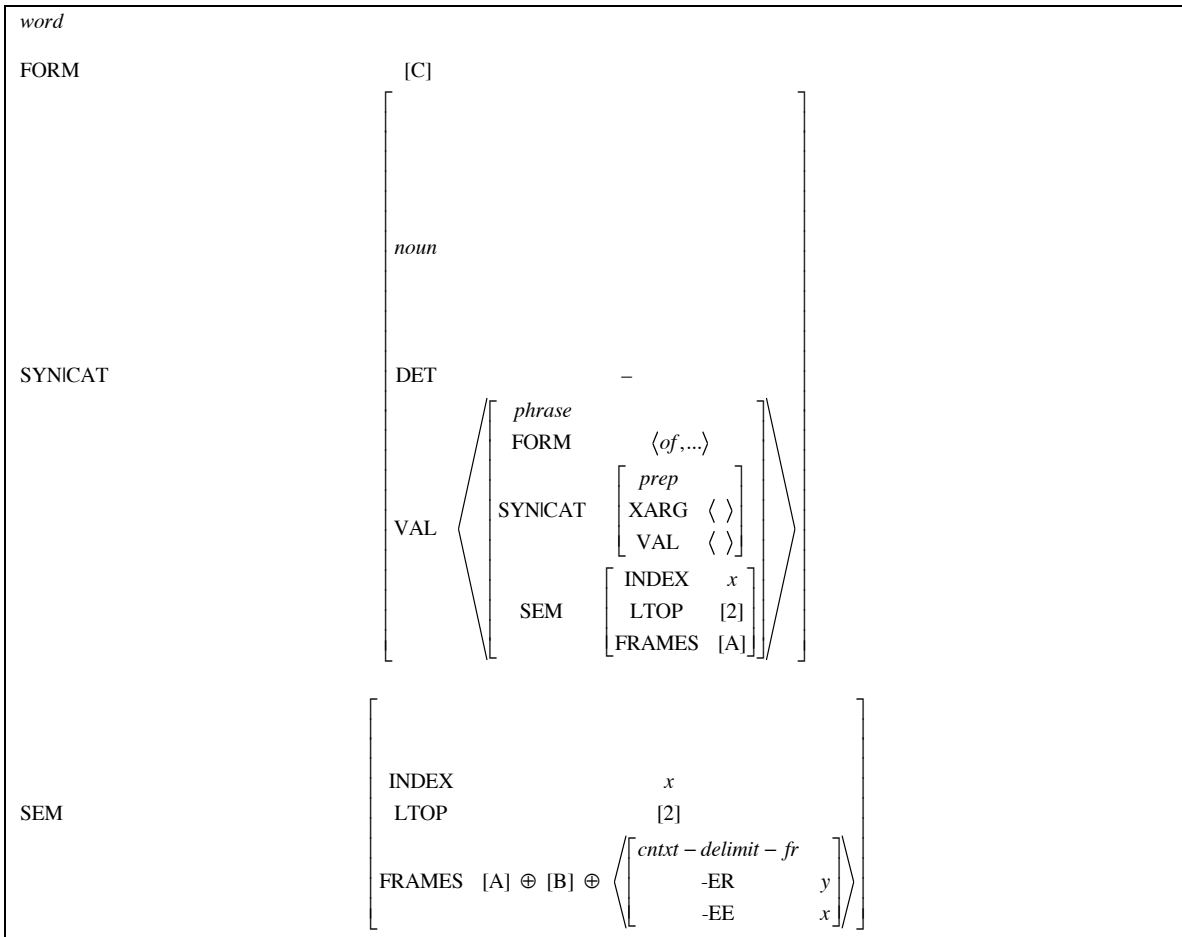

transparent-noun-cxn \Rightarrow

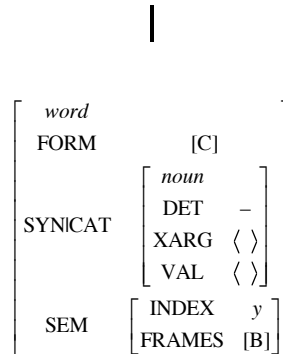

(Please forgive the ugly word processing.) I've used the FORM feature in a way that won't scale to select a PP[*of*]. We once discussed at one time the old CxG lexical-head feature. I forget what the HPSG-style alternative might be.

EXAMPLE: *cup* in *tasty cup of tea*

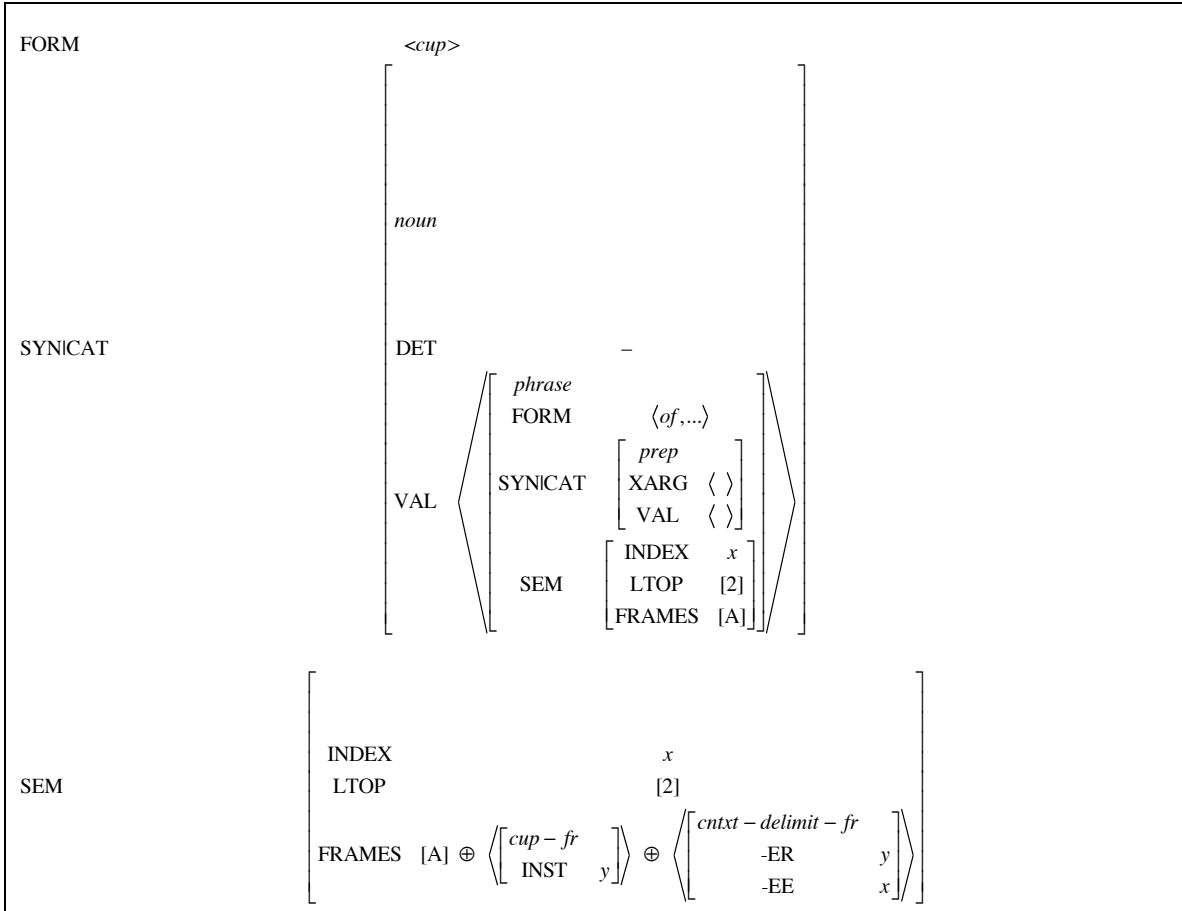

|

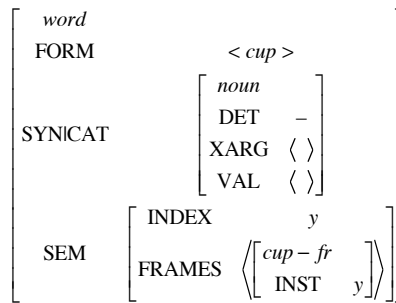

DNI

Here's a shot at an approach to null complement anaphora and DNI in particular. For simplicity, I'll talk just about dni first and then try to generalize to null complements. Assume that every sign with a VAL list also has a (possibly empty) N(u)lCOMP(lement)S list, each of whose members is a Null Complement Anaphor (*nca*). *dni* is a subtype of *nca*. The FS of a *nca* contains a single feature [INDEX *index*].

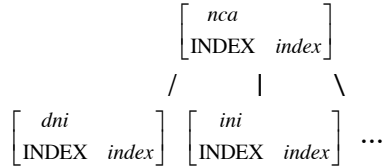

Every member of the NCOMPS is some subtype of *nca* and is constrained to share an index with a member of the VAL list.

$$(6) \quad [\text{NCOMPS } \langle \dots [\text{INDEX } x] \dots \rangle \Rightarrow [\text{VAL } \langle \dots [\text{INDEX } x] \dots \rangle]$$

Here's a dni pumping cxn.

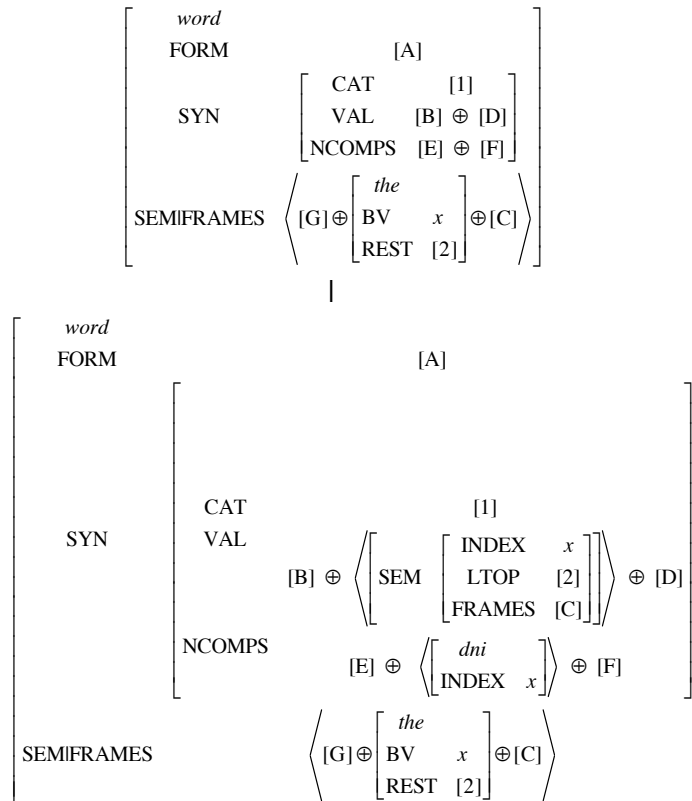

(Sorry things got a little out of line, but I hope you can read it. MathType is the pits. Haven't got time for *nca* generally now, but there are probably enough mistakes in this so far to satisfy anyone's critical faculties.)